

ROFU 8035 SHEARLOCK INSTALLATION MANUAL



The 8035 series is available in two models, the 8035 is unmonitored or the 8035-002 which has hall-effect monitoring. The units may be installed in wood, aluminum, metal or glass doors with or without available housings. This manual gives a guide to all of the above applications and other useful installation information.

ROFU Security International Corp.
10029 South Tacoma Way, E-11
Tacoma, WA 98499
1-800-255-7638
www.rofu.com

1. Full Dimensional Drawing
2. Technical Specification
3. Flush Installation
4. Semi-Flush Installation
5. Surface Installation
6. Full Glass Door Installation

ROFU 8035 Magnetic Lock Assembly

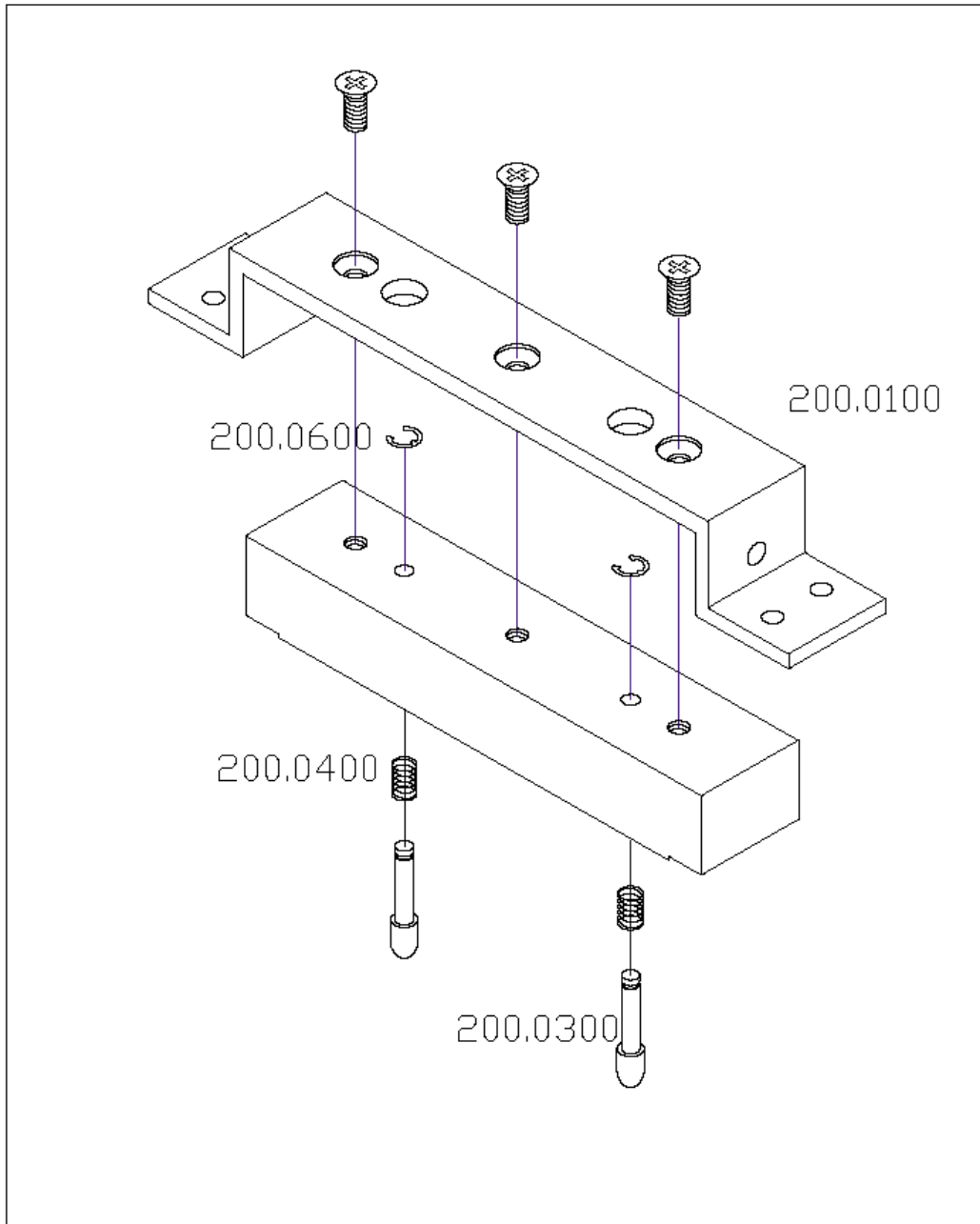

ROFU 8035 Armature Plate Assembly

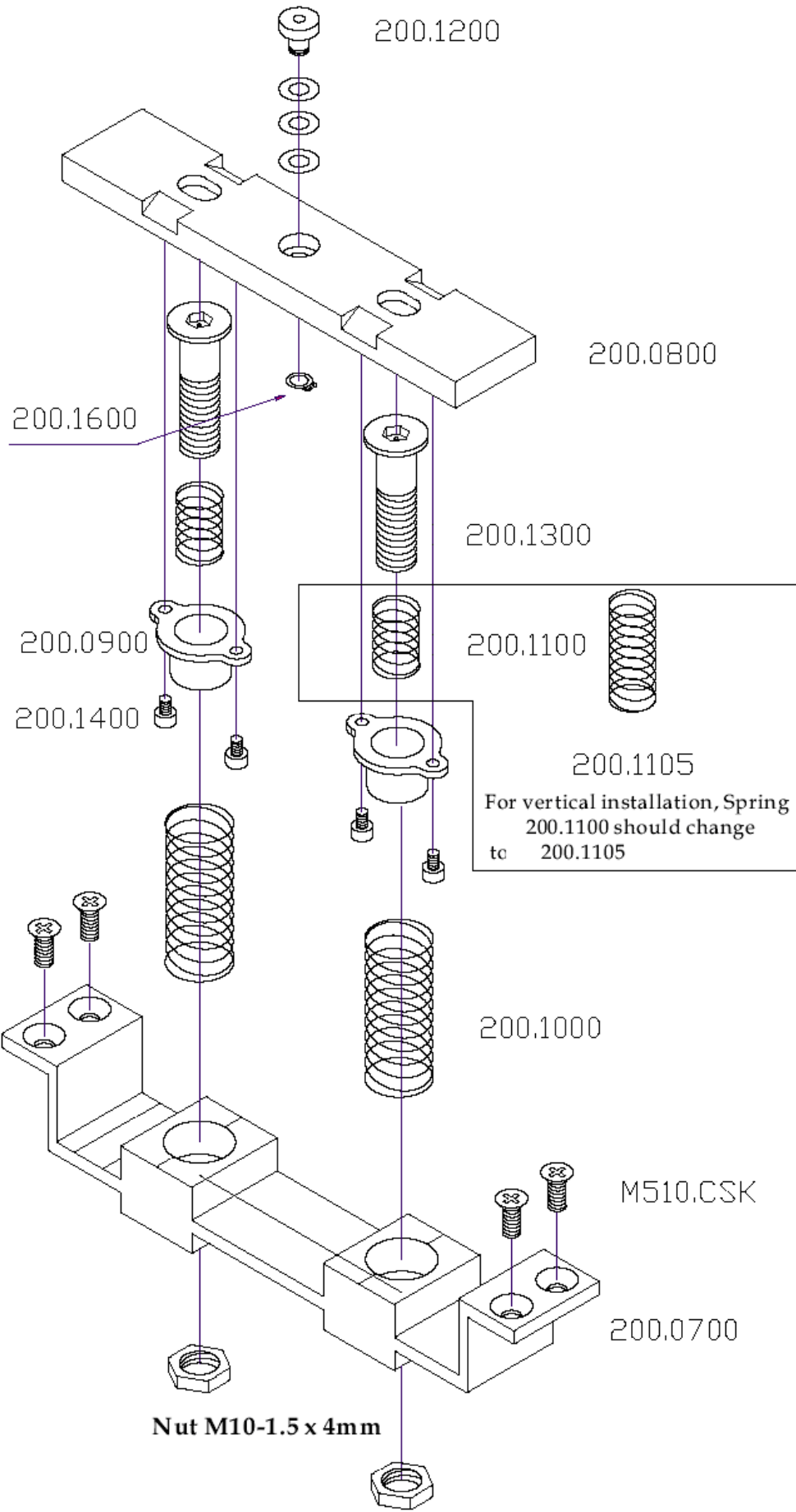

Full Dimension

Magnet Assembly

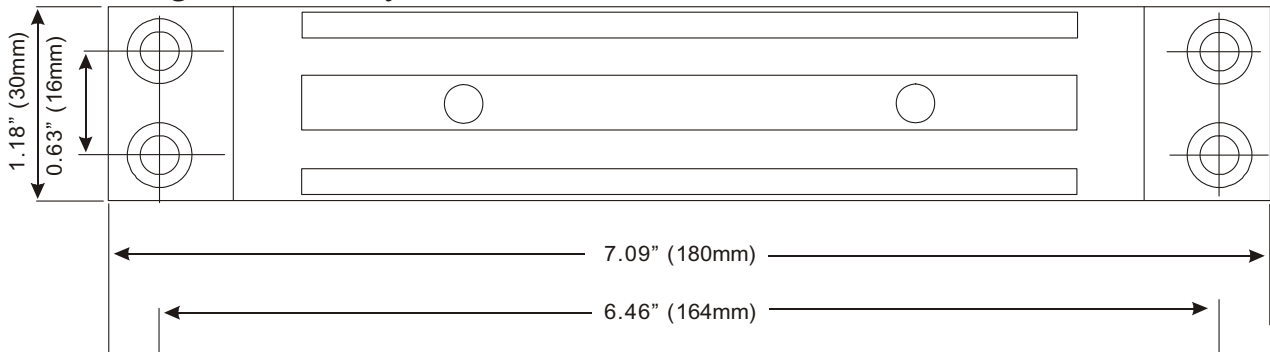

Armature Assembly

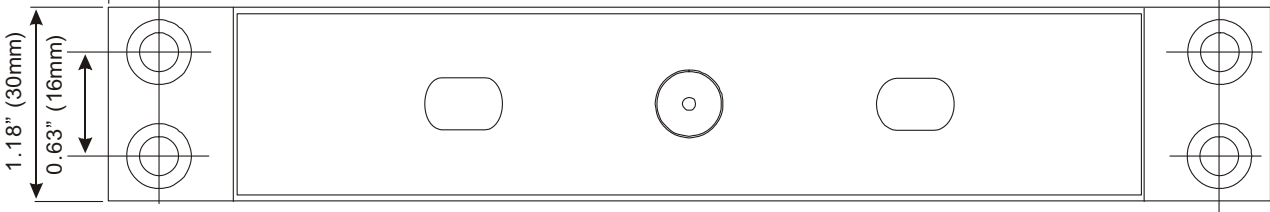

Side View

Magnet Assembly

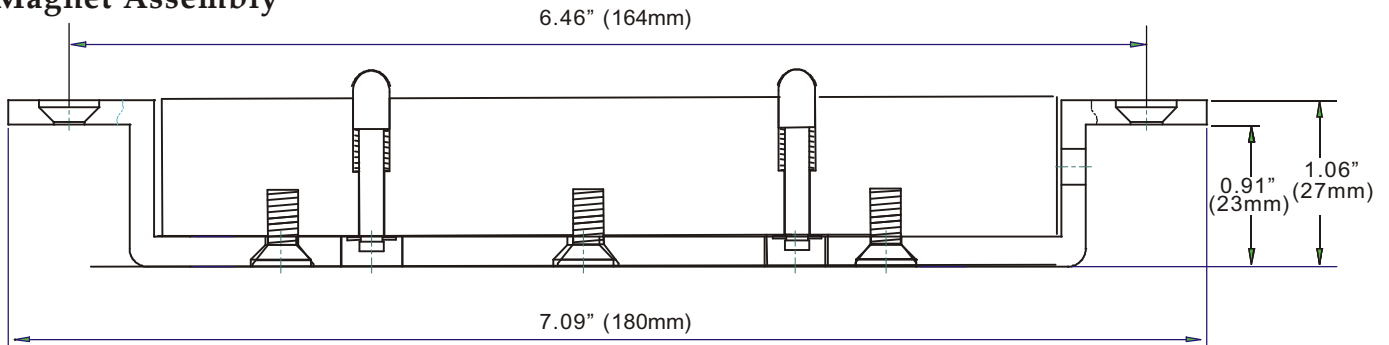

Armature Assembly

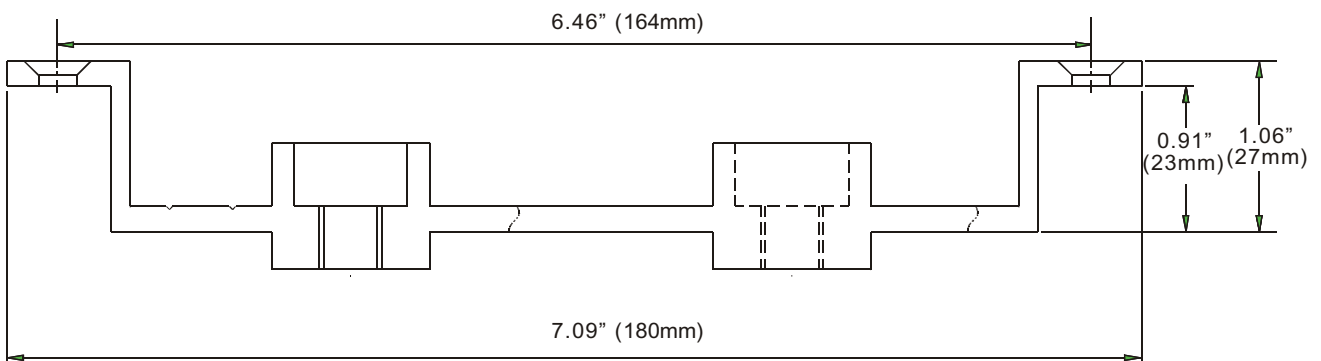

TECHNICAL SPECIFICATION

VOLTAGE

12VDC / 24VDC Selectable via jumpers
 + 10% over voltage is acceptable
 Under voltage will reduce holding force

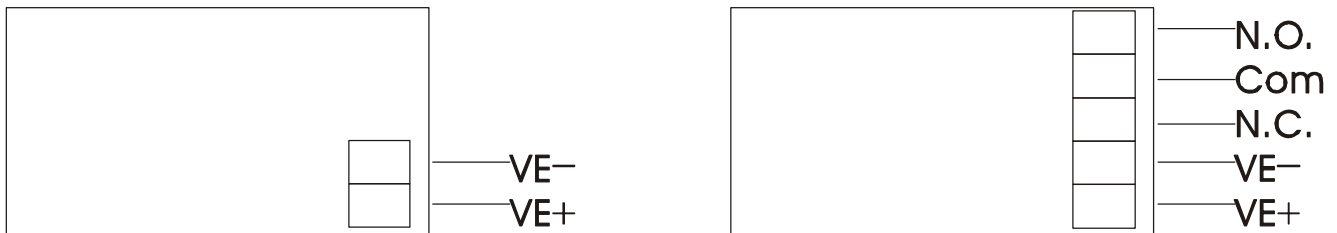
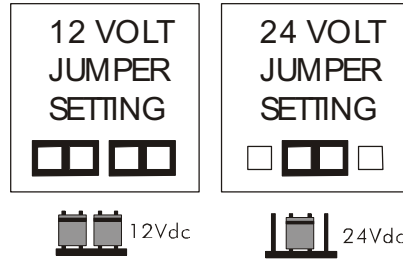

CURRENT CONSUMPTION

350mA @ 12VDC
 190mA @ 24VDC
 The unit does not require an initial voltage
 Increase to operate.

DIMENSIONS

7 1/16" x 1 3/16" x 1 1/16" (180mm x 30mm x 27mm) Magnet
 7 1/16" x 1 3/16" x 1 5/8" (180mm x 30mm x 42mm) Armature
 7 3/16" x 1 7/16" x 1 7/8" (182mm x 36mm x 48mm) SMB200-HOUSING

OPERATING TEMPERATURE -30C to +50F

HOLDING FORCE: Up to 1500 lbs (680 kgs) in shear.
 DYNAMIC STRENGTH FORCE: Up to 70 ft-lbs.

NOTE: THE LOCK SHOULD BE POWERED BY A LISTED UL603 / UL1023 POWER SUPPLY UNIT FOR USE WITH BURGLARY ALARM SYSTEMS.

Model	Wire Gauge	Number of Turns	Maximum Electric Resistant at 20°C (Ω)
8035	0.01" (0.23 mm)	420 Double Turns	25.3

FLUSH INSTALLATION

The unit is designed to be flush mounted. The magnet should be fitted into the header (jamb) and the armature plate into the top of the door.

It is vital that a minimum gap of 1/16" (2mm) exists between the magnet and the armature, to allow correct operation.

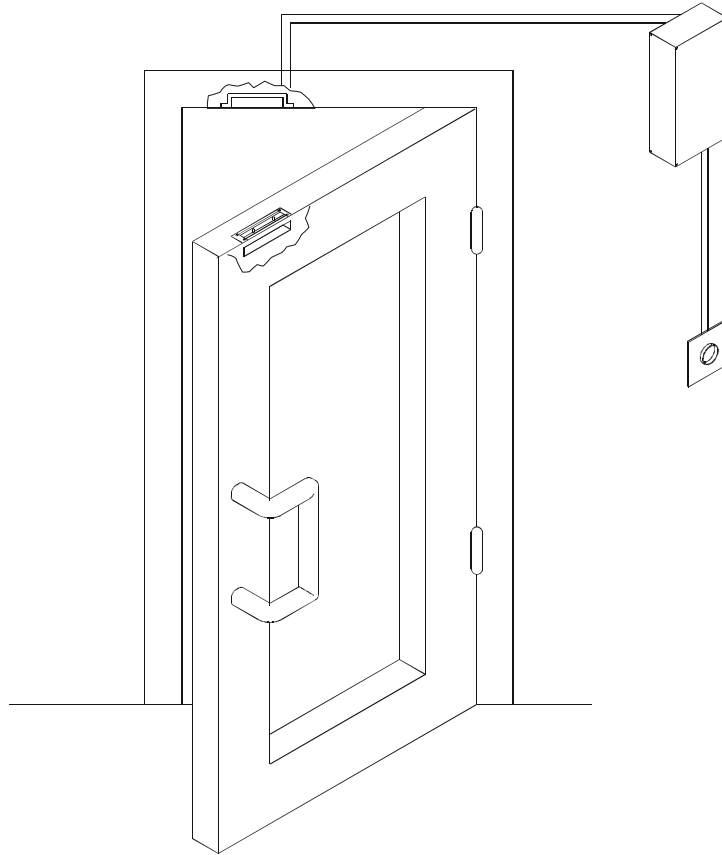

Adjustment of Mini Shear Lock

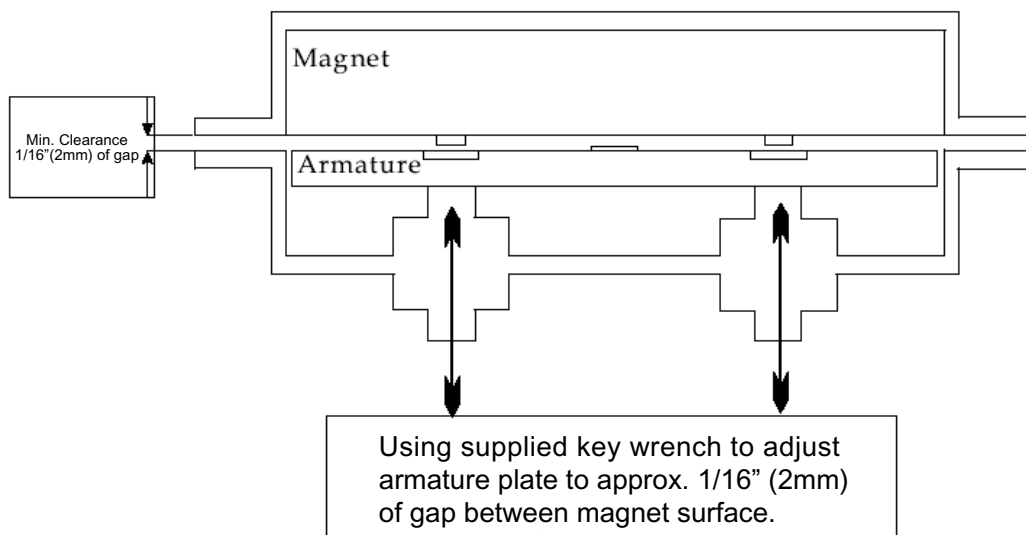

SEMI-FLUSH INSTALLATION

The unit may also be fitted semi-flush with the use of the 21036 housing. The magnet should be fitted to the door transom and the housing holding the armature on to the door.

It is vital that a minimum gap of 1/16" (2mm) exists between the magnet and the armature, to allow correct operation.

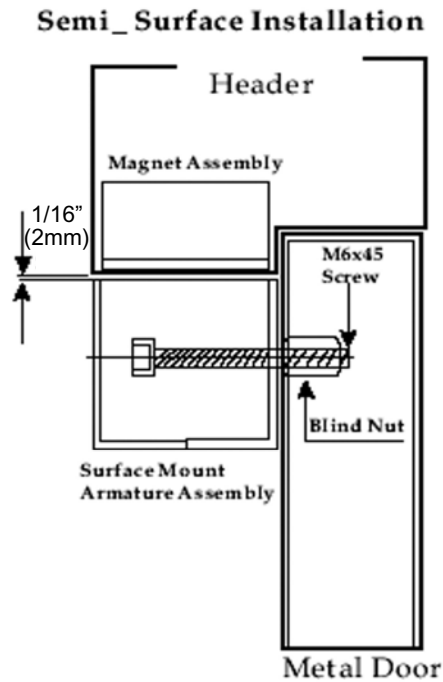

Adjustment of Mini Shear Lock

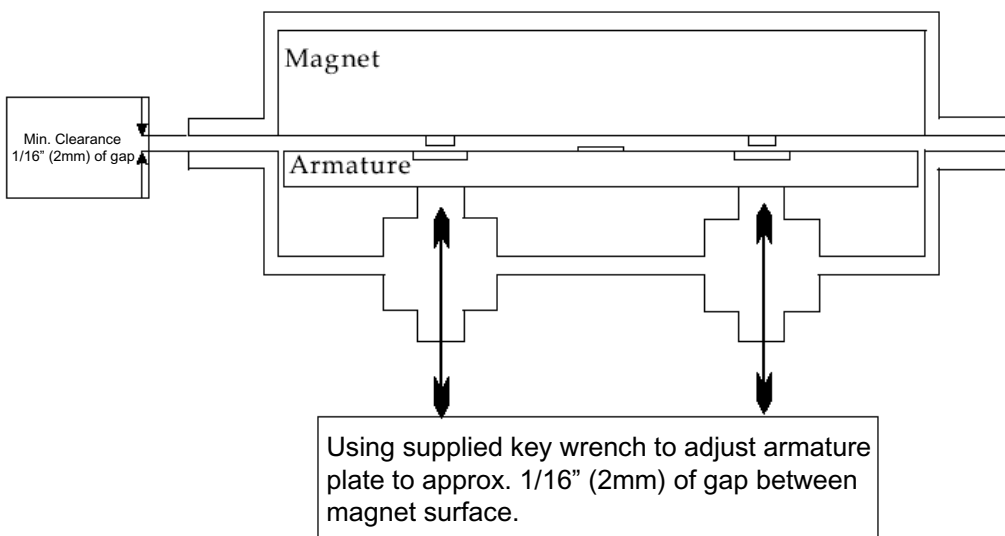

SURFACE INSTALLATION

The unit may also be fitted surface mounted using 2pcs of the 21036 or 21054 (Tamperproof) housing. The housing holding the magnet should be fitted above the door and the housing holding the armature on to the door.

It is vital that a minimum gap of 1/16" (2mm) exists between the magnet and the armature, to allow correct operation.

Surface Mount Installation

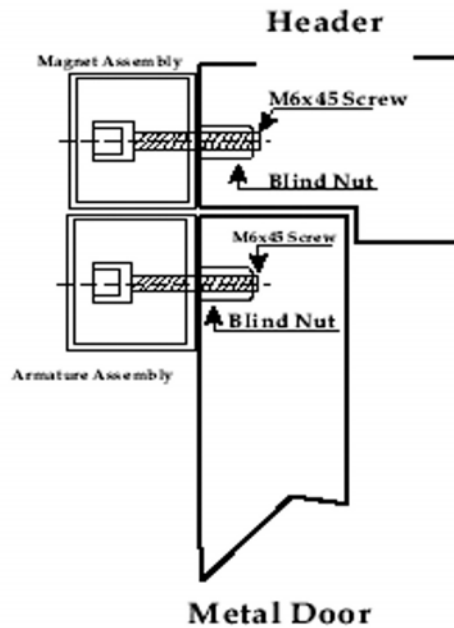

Adjustment of Mini Shear Lock

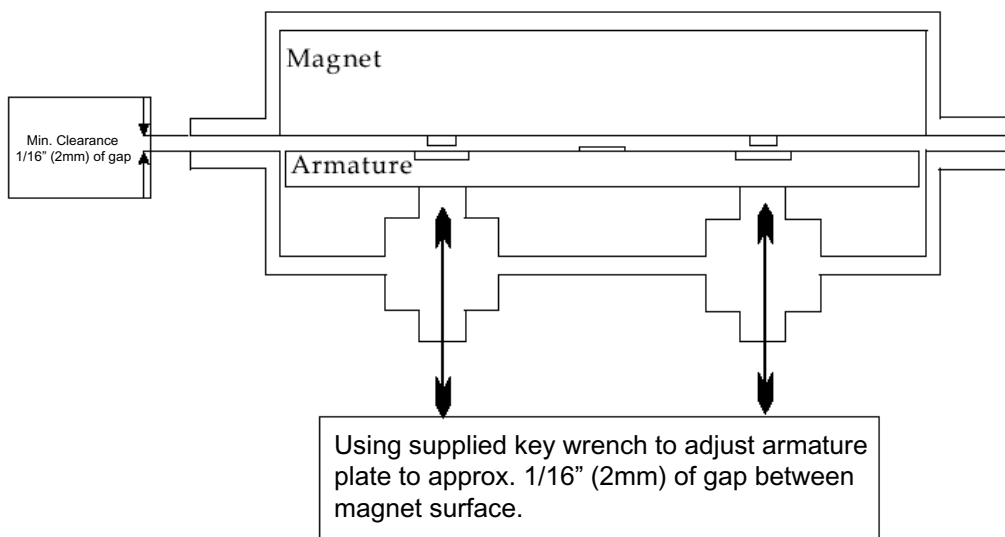

FULL GLASS DOOR INSTALLATION (NOT VERIFIED BY UL)

The unit may also be fitted to a full glass door and glass frame application, using 2pcs of the 21036 housing and 2pcs of the 21037 U-brackets. The housing holding the magnet should be clapped above the door and the housing holding the armature clapped on to the door.

It is vital that a minimum gap of 1/16" (2mm) exists between the magnet and the armature, to allow correct operation.

Installation on Full Glass Door

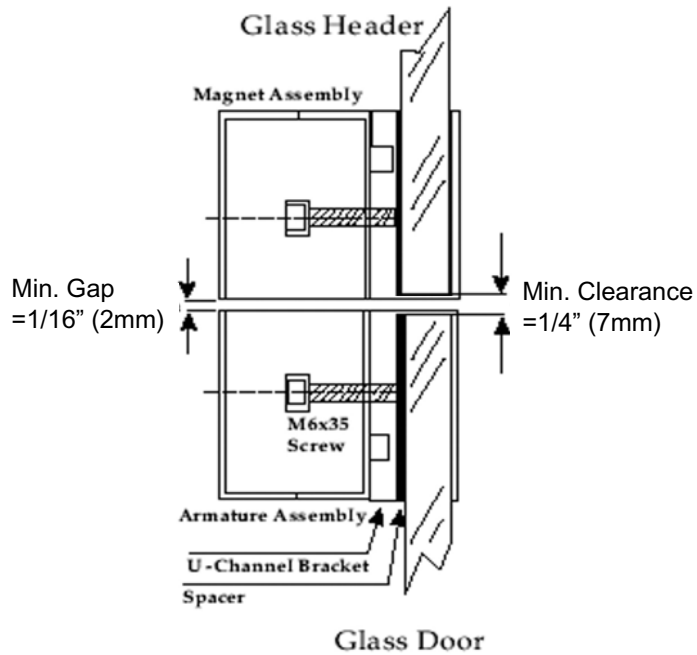

Adjustment of Mini Shear Lock

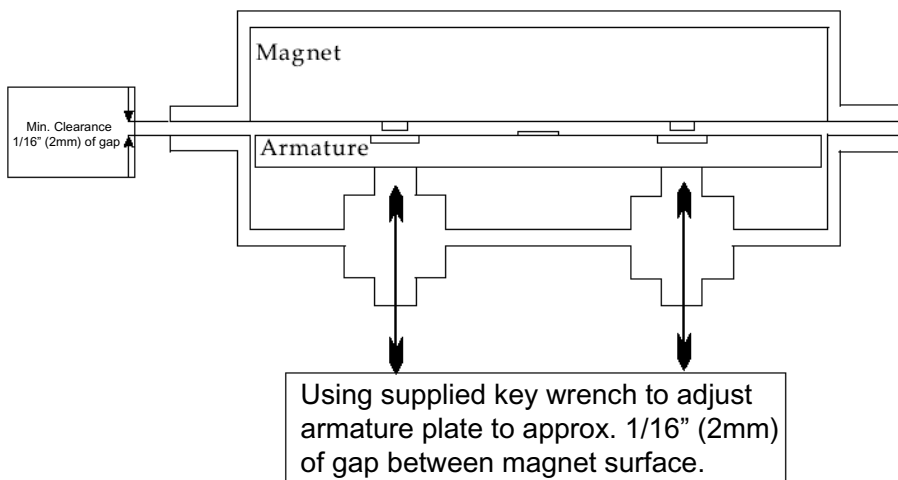

NOTICE:

